

Muto Premium XL120

Glass mount with Dormotion and Self-Close

Supplemental Installation instructions

936017 – 06-2021

| EN |

dormakaba 

Table of contents

1	Technical specifications	3
1.1	Overview	3
	1.1.1 General information	3
	1.1.2 Intended use	3
	1.1.3 Glass requirements and fittings	3
	1.1.4 Requirements for glass panel	3
	1.1.5 Safety instructions	3
	1.1.6 Symbols used - Safety/Installation	3
	1.1.7 Maintenance, care, repair	3
	1.1.8 Disposal	3
1.2	Specifications - technical data	4
1.3	Tempered laminate glass (TLG) and adhesive specifications	4
2	Installation instructions	5
2.1	Overall	5
2.2	Glass door prep - single door mount	6
2.3	Glass door prep - double door mount	7
2.4	Door/wall dimensions	8
2.5	Preparing track	9
2.6	Secure glass clamp profile and track to glass mounting surface	9
2.7	Secure glass clamp profile end caps	10

1 Technical specifications

1.1 Overview

These instructions are for installation of MUTO PREMIUM sliding door system XL120 for the following mounting and style versions:

1. Glass mount

1.1.1 General information

- dormakaba requires use of tempered monolithic or tempered laminated glass.
- dormakaba glass hardware is not suitable for application in rooms where chemicals (e.g. chlorine) are used as indoor swimming pools, saunas or salt-water pools.
- Never move sliding panels faster than walking speed and always stop the door manually before it reaches end position.
- Do not slide doors with excessive force. Install limiting stop to prevent door from opening too far.

1.1.2 Intended use

- For sliding door in dry indoor areas only
- For manual slowly opening and closing only

1.1.3 Glass requirements and fittings

- The substructure/wall must be able to bear permanent loads and be level (max. tolerance: 1/16" [2] per 39" [1m]).
- Fasteners must be sufficiently dimensioned for the substructure/wall and weight of the door.
- When adjusting glass components, always stick to the required clearance for the respective hardware. Adjust clearance so glass does not come in contact with any hard surfaces such as glass, metal or concrete.
- Do not use excessive force when installing the glass (avoid over tightening screws).

1.1.4 Requirements for glass panel

- dormakaba requires use of fully tempered glass, which complies with ASTM C 1036 and ASTM C 1048. Secondary heat soaking processes are optional but not required. This applies to both tempered monolithic and tempered laminated glass.
- Clamping area must be flat and uncoated (no self-cleaning coating!)
- Never use glass with conchoidal fractures and/or damaged edges.

1.1.5 Safety instructions

- Installation requires two people.

- Only properly qualified and specially trained staff are authorized to mount dormakaba glass hardware.
- Due to crushing hazards and possible injury caused by breakage of glass during mounting, corresponding protective clothing (especially gloves and protective goggles) is required.
- Never clamp metal fitting hardware directly to glass surface.

1.1.6 Symbols used - Safety/Installation



CAUTION

Mounting components must meet the requirements of substructure/wall and door weight. Please read the technical information for fittings.



WARNING

Risk of breaking glass. When installing the door, support the door panel with a block of wood or similar object.



TIPS AND RECOMMENDATIONS

Information note



CLOSING EDGE

1.1.7 Maintenance, care, repair

- Immediately replace damaged parts.
- Always use original dormakaba parts.
- Clean clamping area with alcohol-based standard commercial cleaning agent before mounting the glass hardware.
- Use a damp cloth for occasional cleaning, especially the track.
- Always use silicone - and oil-free cleaners (e.g. acetone).
- Check glass hardware at regular intervals for proper positioning and smooth operation and correct adjustment.
- High traffic door systems require inspection by properly qualified staff (specialized companies or installation firms.)

1.1.8 Disposal

Disposal in accordance with local, state and national regulations.

1.2 Specifications - technical data

		Single Door	Double Door
		XL120	XL120
Glass mount	Door leaf weight lbs [kg]*	≤264lbs [≤120]	2 x ≤264lbs [2 x ≤120]

* Including weight of auxiliary hardware.

1.3 Tempered laminate glass (TLG) and adhesive specifications

Required parts for laminate glass with MUTO System (not included)	Part Number	Quantity	Usage recommendation
3M™ Scotch-Weld™ Urethane Adhesive, DP 605 NS	934.800	1 tube	1 tube per 4 roller carriers
3M™ Scotch-Weld™ EPX™ Plus II Applicator with 1:1 Plunger ²	934.801	1 applicator	1:1 plunger with 934.800 adhesive
3M™ Scotch-Weld™ EPX™ Plus II Mixing Square Nozzle, 5.3mm ³	934.805	Pk of 4	4 nozzles per 1 tube of adhesive
MUTO TLG gasket set	807.640	1 set	
Handling time frame	Function	Time	
	Working life (<i>time between application and clamping of carrier</i>)	5 minutes @ 75°F	
	Handling strength	20 minutes @ 73°F or more	
	Full cure time (<i>normal door usage not recommended until full cure time as been met</i>)	48 hours @ 73°F or more	

NOTE: Door glass should not be installed until the full cure time as been reached (see chart above).

Important safety-related information for the mounting and use of dormakaba glass hardware.

1.1 Clean clamping area with alcohol-based standard commercial cleaning agent before mounting the glass hardware.

1.2 Never clamp metal glass fitting hardware directly to glass surface.

1.3 Never use clamping product on surfaces with self-cleaning coatings.

² Scotch-Weld™ EPX™ Plus II Applicator with 1:1 Plunger is a trademark of 3M.

³ Scotch-Weld™ EPX™ Plus II Mixing Square Nozzle is a trademark of 3M.

2 Installation instructions

2.1 Overall

Fig. 1

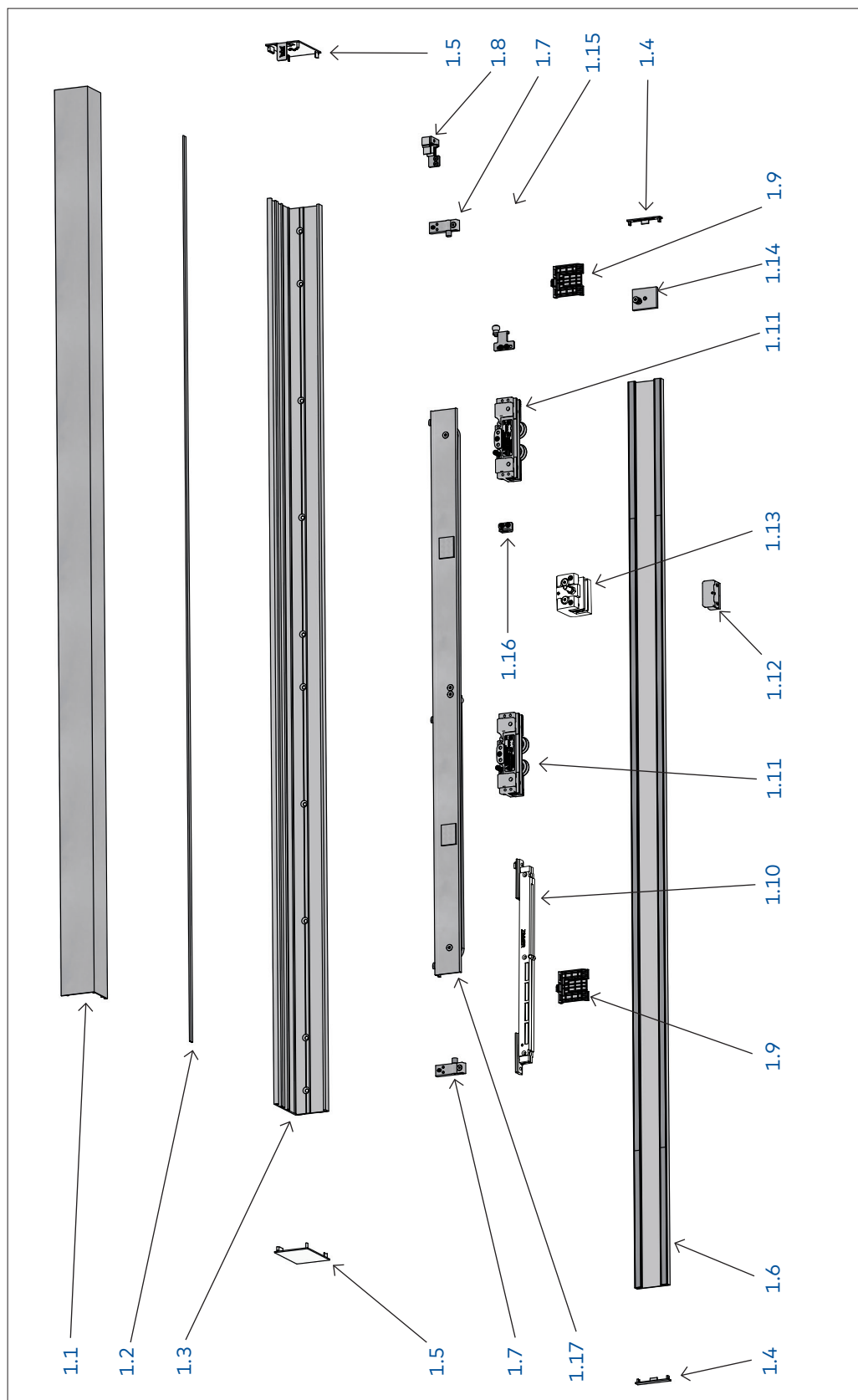

- 1.1 Cover
- 1.2 Brush strip
- 1.3 Track
- 1.4 End cap (glass clamp profile)
- 1.5 End cap (track)
- 1.6 Glass clamp profile
- 1.7 End stop
- 1.8 Self-close hold open clamp
- 1.9 End stop
- 1.10 Dormotion unit
- 1.11 Roller carrier
- 1.12 Floor guide
- 1.13 Start/stop
- 1.14 Clamping plates
- 1.15 Self-close hold open ball
- 1.16 Self-close cable connector
- 1.17 Self-close cable unit

2.2 Glass door prep - single door mount

Fig. 2

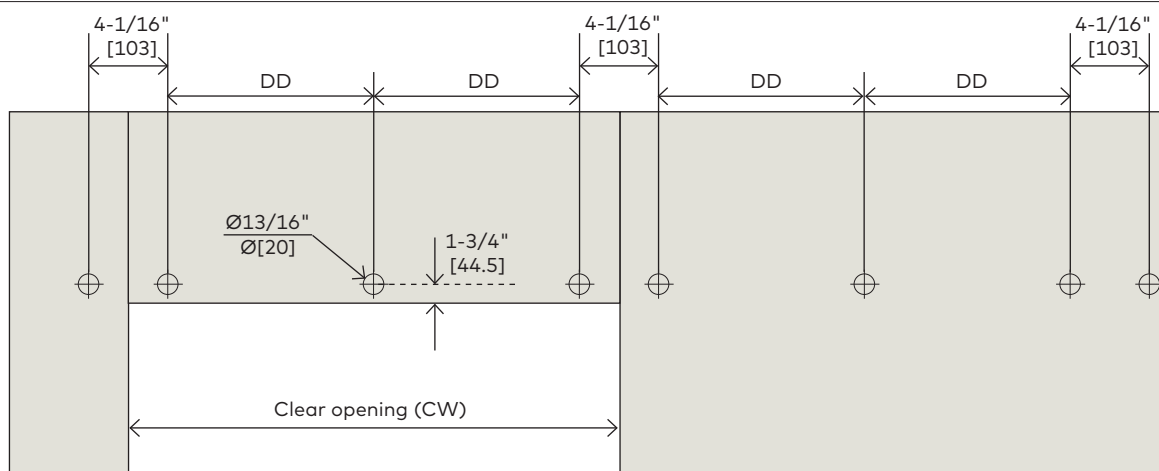

2.2.1 Use the equation at the right to determine the 'drilling distance' [DD] between each hole.

$$DD = (CW - 106) / T$$

2.2.2 First find the measured 'clear opening width' [CW] on the chart at the right.

2.2.3 Determine 'T' for the equation.

2.2.4 Insert appropriate values into equation and calculate accordingly.

Clear opening width	T	QHP
CW ≥ 23-5/8" [600] CW ≤ 31-1/2" [800]	2	8
CW > 31-1/2" [800] CW ≤ 39-3/8" [1000]	3	10
CW > 39-3/8" [1000] CW ≤ 47-1/4" [1200]	4	12
CW > 47-1/4" [1200] CW ≤ 59-1/16" [1500]	5	14

SEE LEGEND BELOW FOR REFERENCE.

LEGEND	
Abbreviation	Description
CW	Clear opening width
DD	Drilling distance
T	Division variable
QHP	Qty of hole preps

XL Dormotion 120	
Min. door width	33-1/2" [850]
Min. clear opening width	31-1/8" [790]
Max. door width	57" [1448]
Max. clear opening width	54-5/8" [1388]

2.3 Glass door prep - double door mount

Fig. 3

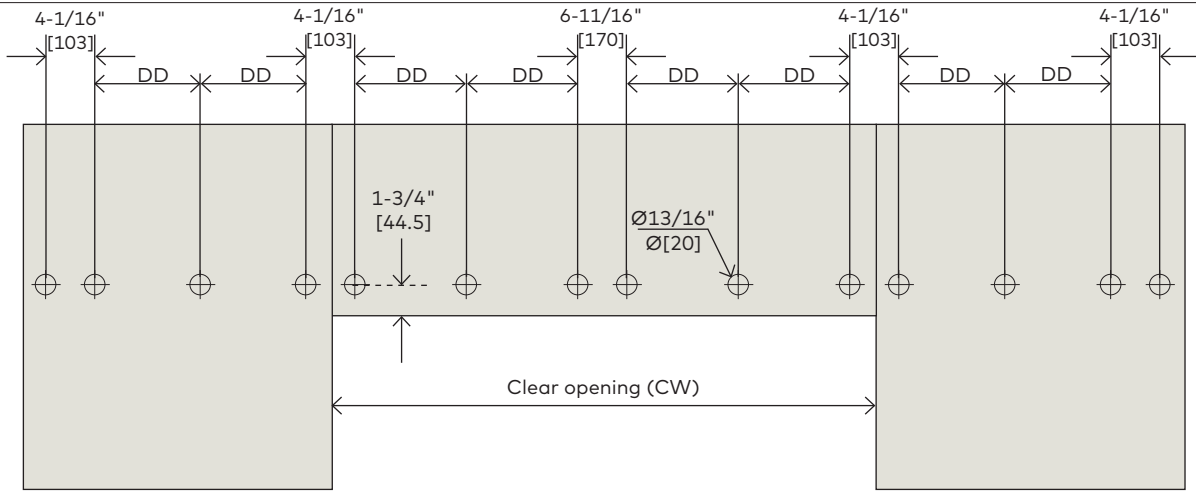

2.2.1 Use the equation at the right to determine the 'drilling distance' [DD] between each hole.

$$DD = (CW - 106 - 170) / T$$

2.2.2 First find the measured 'clear opening width' [CW] on the chart at the right.

2.2.3 Determine 'T' for the equation.

2.2.4 Insert appropriate values into equation and calculate accordingly.

Clear opening width	T	QHP
CW ≥ 47-1/4" [1200] CW ≤ 59-1/16" [1500]	4	14
CW > 59-1/16" [1500] CW ≤ 78-3/4" [2000]	6	18
CW > 78-3/4" [2000] CW ≤ 114-3/16" [2900]	8	22

SEE LEGEND BELOW FOR REFERENCE.

LEGEND	
Abbreviation	Description
CW	Clear opening width
DD	Drilling distance
T	Division variable
QHP	Qty of hole preps

XL Dormotion 120	
Min. door width w/dormotion	33-1/2" [850]
Min. clear opening width w/dormotion	64-13/16" [1646]
Max. door width	57" [1448]
Max. clear opening width	111-7/8" [2842]

2.4 Door/wall dimensions

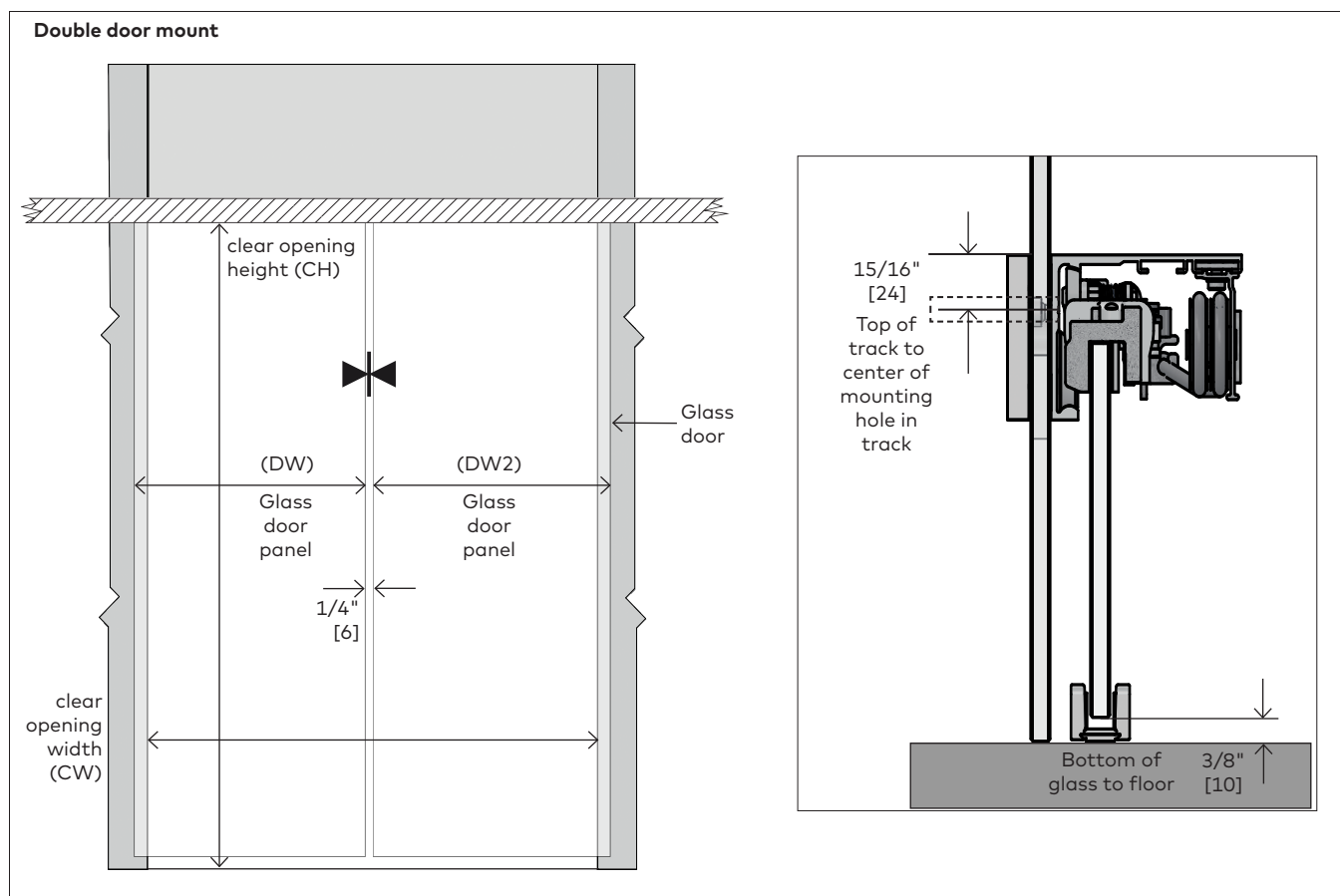
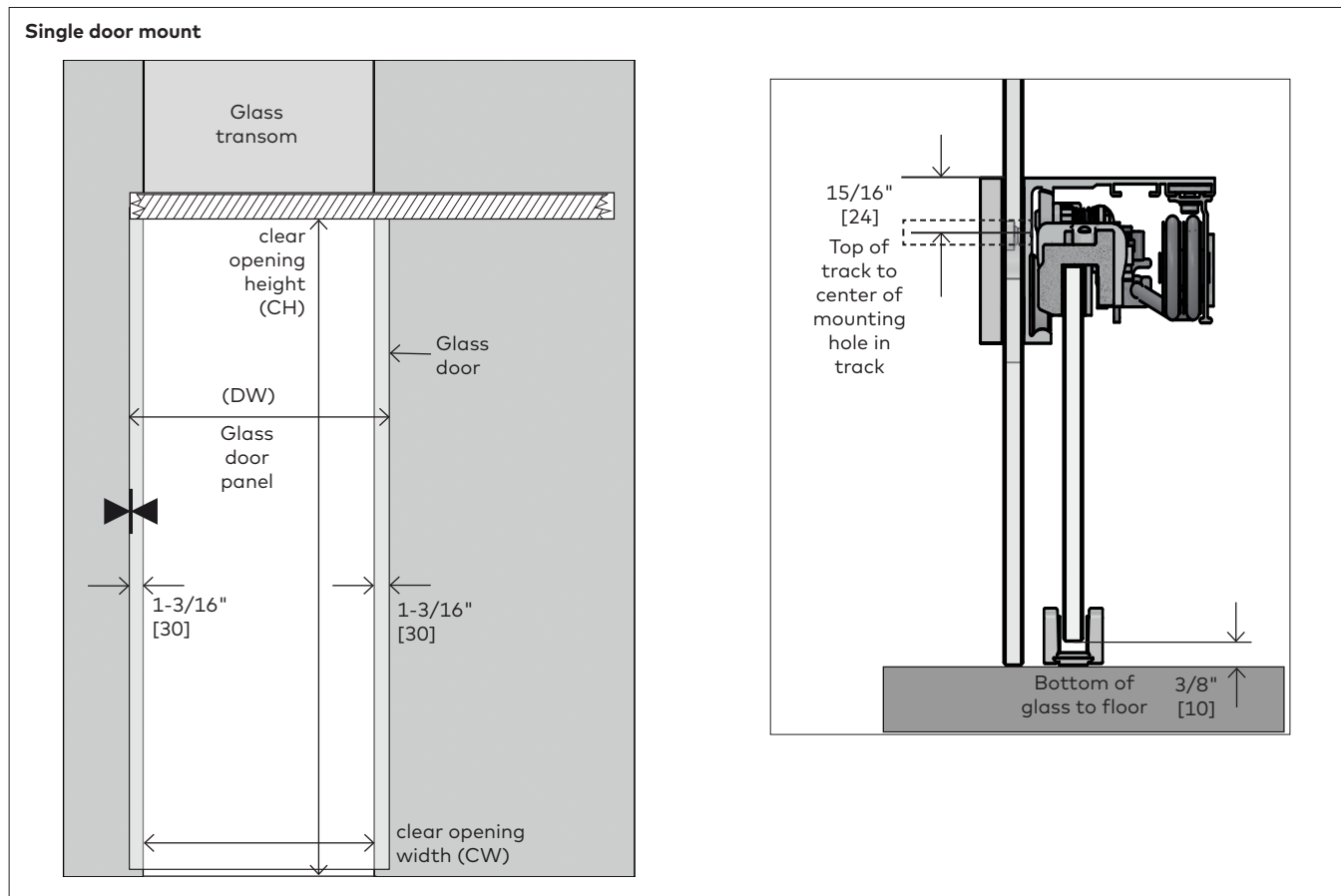

2.5 Preparing track

Fig. 4

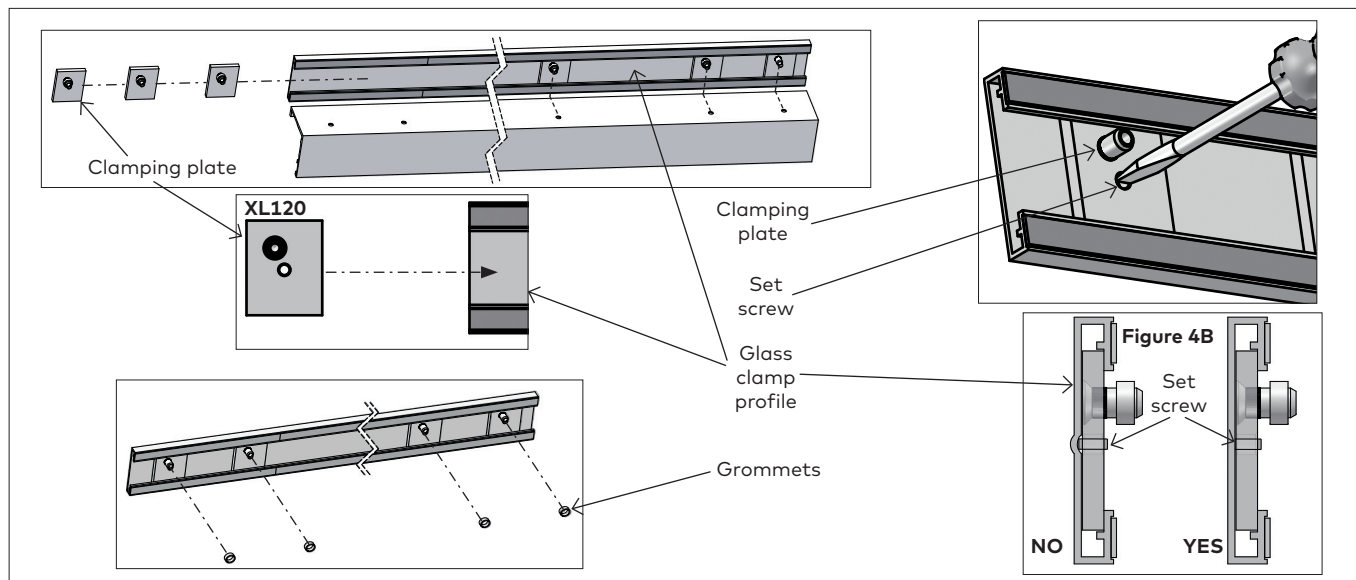

2.5.1 Slide clamping plates into end of glass clamp profile.

NOTE: Quantity dependent upon number of holes in track.

2.5.2 Orient plates properly as shown above; L80 or XL150/80.

2.5.3 Secure via set screw.

NOTE: Be sure set screw does not indent back of glass clamp profile. See Figure 4B for reference.

2.5.4 Secure grommets to each clamping plate peg.

2.6 Secure glass clamp profile and track to glass mounting surface

Fig. 5

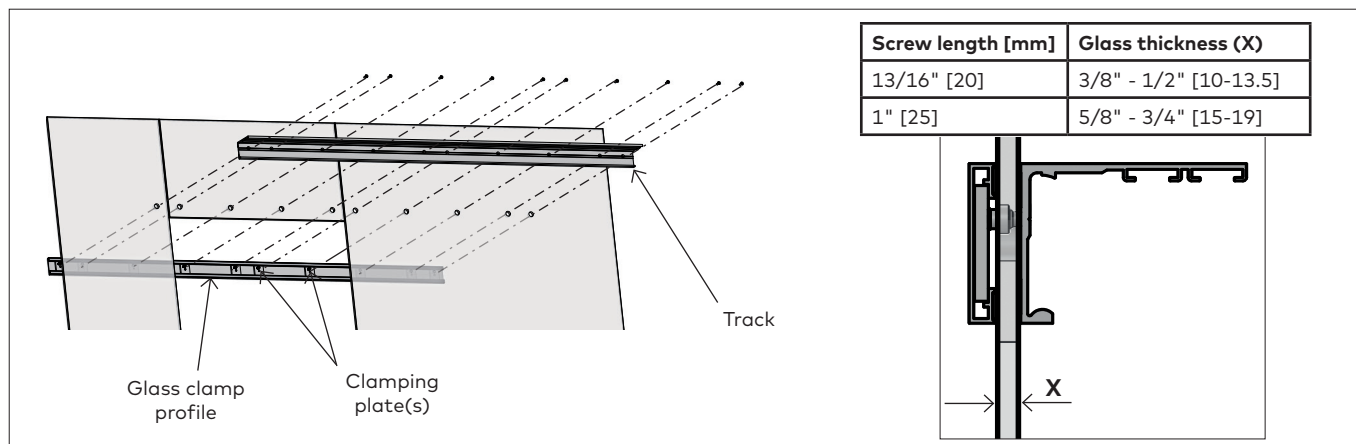

2.6.1 Ensure track is properly level.

2.6.2 Align clamping plates and track through glass mounting surface.

2.6.3 Secure with proper fasteners per chart above.

NOTE: SEE DIMENSION INSTRUCTIONS ON PRIOR PAGE FOR REFERENCE.

2.7 Secure glass clamp profile end caps

Fig. 6

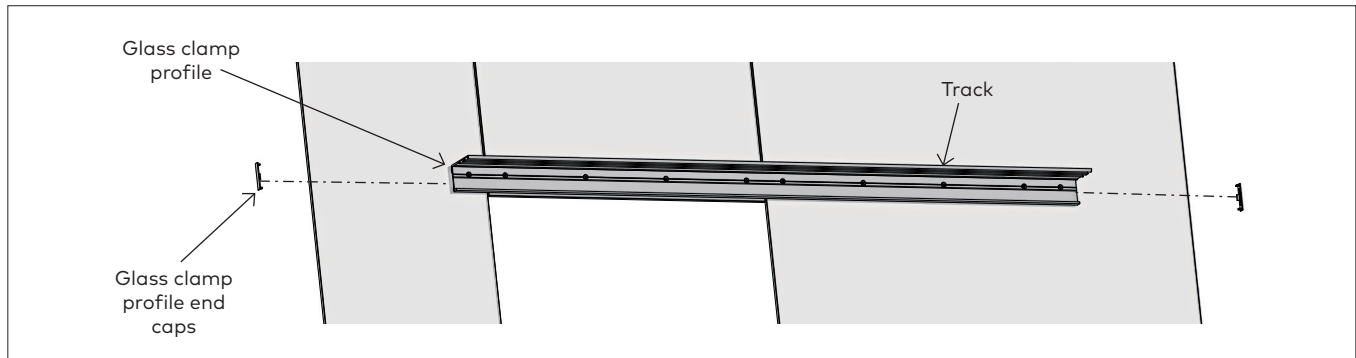

2.7.1 Slide glass clamp profile end caps into ends of glass clamp profile.

2.7.2 Install remaining MUTO product as per standard instructions included.



INSTALL REMAINING MUTO PRODUCT AS PER STANDARD INSTRUCTIONS INCLUDED.

